

Transputer based data acquisition system for the CMD-2 detector ^{*}

G.A. Aksenov^a, V.S. Banzarov^a, T.B. Bolshakov^a, A.G. Chertovskikh^{a,*}, S. Levitan^b,
I.B. Logashenko^a, A.V. Maksimov^a, Yu.I. Merzlyakov^a, V.A. Monich^a, V.V. Shilo^a,
E.P. Solodov^a, I.V. Sorokin^a, J.A. Thompson^b, C.M. Valine^b, V.G. Zavarzin^a

^a Budker Institute of Nuclear Physics, Novosibirsk, 630090, Russia

^b University of Pittsburgh, Pittsburgh, PA 15260, USA

Abstract

CMD-2 [1] is currently studying e^+e^- annihilation in the energy range from 0.36 GeV to 1.4 GeV. The planned upgrade [2] of the VEPP-2M collider facility will increase the luminosity of the machine from $5 \times 10^{30} \text{ cm}^{-2}\text{s}^{-1}$ up to $2 \times 10^{31}\text{--}10^{32}$. The expected increase in data rates is beyond the capacity of the operational data acquisition system (DAQ) and necessitates the design of a new system.

1. Introduction

At present, the DAQ [3] reads out from digitizing electronics events with an average size of about 2 Kbyte and passes the data to the custom built AP-32 processor for third-level triggering before recording to EXABYTE tape with data rates of about 50 Kbyte/s. The primary design goal for the new DAQ is the ability to handle the data rates expected with the accelerator upgrade and the ability to scale beyond these increases. The most immediate upgrade will result in an increase of the maximum read-out speed from 200 Kbyte/s (100 events/s) to about 1.4 Mbyte/s (700 events/s) passing the first and second level (hardware) triggers. The third-level (software) trigger will keep the rate of events recorded to a magnetic medium at an acceptable level of about 250 Kbyte/s. The peak recording rate will also be increased to 500 Kbyte/s.

- (ii) The CAMAC system which is responsible for gathering information from the KLUKVA system, event building, and passing data to the microprocessor (transputer) farm.
- (iii) The transputer farm which receives the built events from the CAMAC system and filters out background using the third level trigger algorithms.
- (iv) The VME master which records events to a magnetic medium and passes some events on to remote computers for real-time analysis.

The CAMAC controller was the only component upgraded in the CAMAC system. The new CAMAC controller is based on an INMOS T425 microprocessor. It is connected to the transputer farm via transputer links and can be treated as an element of the transputer network. The

2. Hardware

The new DAQ (see Fig. 1) can be divided into several subsystems or stages of data processing:

- (i) The hardware of the first level trigger (which will be upgraded in the new DAQ) and digitizing electronics – the KLUKVA system [4].

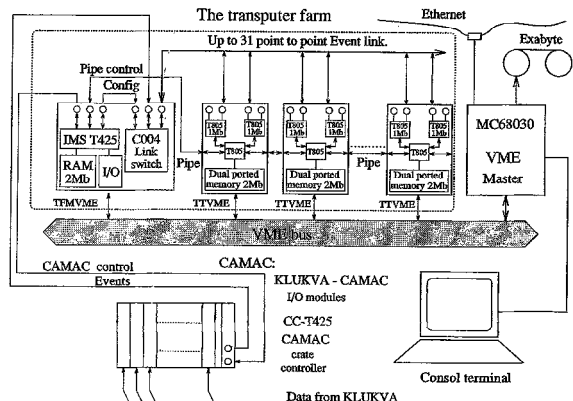

Fig. 1. The transputer farm.

^{*} This work is supported in part by ISF under the grants RPT000 and RPT300, by grants DOE and NSF (USA), and by grants of Russian Government.

^{*} Corresponding author. Fax +7 3832 352163, e-mail chertovs@inp.nsk.su

controller receives and handles interrupts from front-end digitizing electronics.

The transputer farm (see Fig. 1) occupies one VME crate and consists of one to eight TTVME "farm slave" modules and a TFMVME "farm master", all of them being VME slaves. The "farm master" has one INMOS T425 transputer, an INMOS C004 crossbar link switch, and a special link interface to the VME bus. The "farm master" controls all data transfers between the CAMAC system and the transputer farm by configuring the crossbar switch. It also controls the event flow to the VME master by setting interrupts on the VME bus which are serviced by the VME master.

Each TTVME module has up to three INMOS T805 transputers. Two of them are connected to the INMOS crossbar switch and the other one is equipped with dual ported memory which can also be read from the VME master via VME bus. All the "farm slaves" are connected to the "farm master" via links in a daisy chain manner.

The VME master reads events that pass the third level trigger, records them to a magnetic medium, displays a small percent of events on the operator's console, and provides a user interface to the data acquisition system. It is comprised of a Motorola MC68030 based VME unit with a 340 Mbyte hard drive, floppy drive, and Ethernet adapter. The VME master runs under the OS-9 operating system.

3. Software

The SPIDER package [5] was used as general template for the DAQ. The SPIDER-based DAQ is implemented as a set of co-operating tasks running in the VME master under OS-9. It provides a convenient user interface, reads and

buffers events from the farm, records events to a magnetic medium, sends a certain percentage of events to remote computers for display, and provides convenient tools for debugging. A file server program was also developed under the OS-9 operating system to compile, link and load files to the transputer farm at startup mode. The file server is embedded into the DAQ to serve the transputer farm.

4. Conclusions

The new data acquisition system currently provides a factor of seven increase in the readout speed over the old system. This increase is limited by CAMAC bus throughput. With a more sophisticated hardware trigger (which will also be upgraded) and excess power of the transputer farm for online analysis, this rate will be sufficient for the planned upgrades. A significant increase in the system performance will require the parallelization of both input and output, which can be implemented within the framework of the transputer farm approach.

References

- [1] E.V. Anashkin et al., ICFA Instr. Bull. 5 (1988) p. 18.
- [2] A.N. Filippov et al., Proc. Int. Conf. on the Accelerator Physics, Hamburg, Germany, 1992, p. 1145.
- [3] G.A. Aksenov et al., Proc. Conf. on Computing in High Energy Physics 92, Geneva, Switzerland, December 1992, p. 783.
- [4] V.M. Aulchenko et al., Data acquisition system for new detectors in INP, Proc. Int. Conf. on Calorimetry in High Energy Physics, FNAL, 29 Oct.-1 Nov., 1990.
- [5] J. Petersen, VMEbus/OS-9 Based Data Acquisition System, MMCNL31, July 1991, CERN, Geneva, Switzerland.